

# WARTUNG VON GELENKWELLEN

## SCHMIERPLAN – EUROCARDAN SERIE TEQ UND PLUS

SCHMIERINTERVALLE (STUNDEN) UND UNGEFÄHRE FETTMENGEN

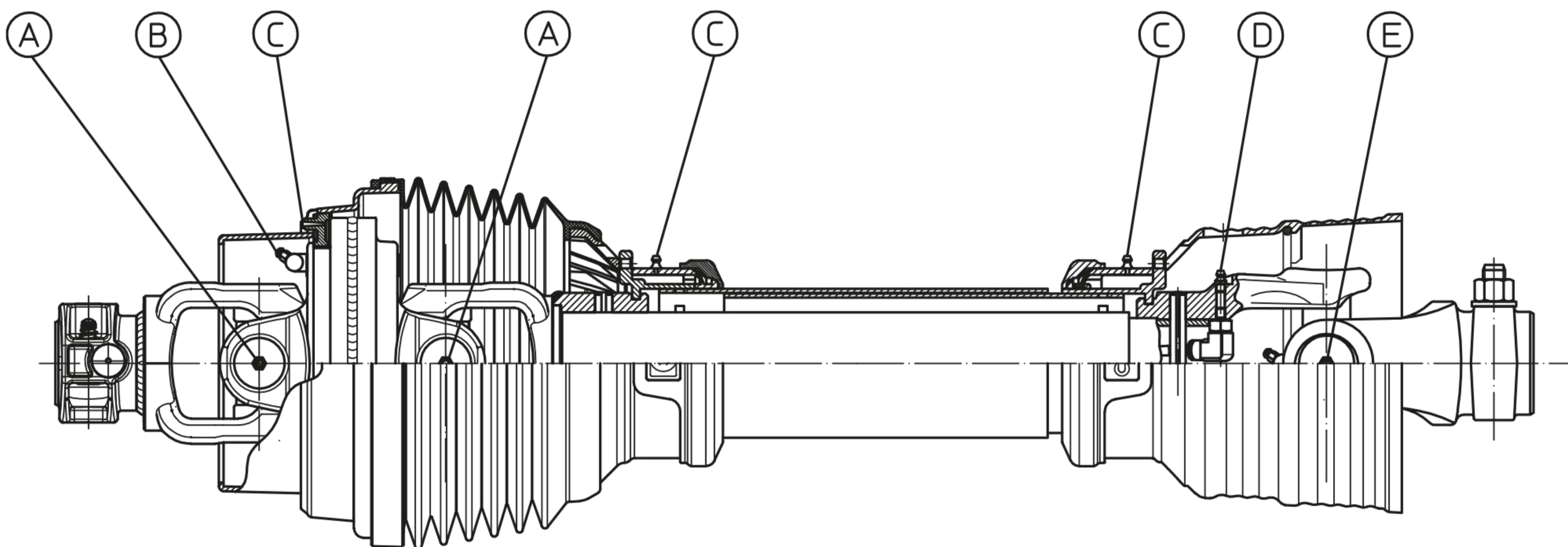

	SCHMIERINTERVALLE (STUNDEN)									
	A WW-Kreuzgelenk		B Weitwinkelgelenk		C Gleitring		D Profilrohr		E Kreuzgelenk	
	Min. *	Max.	Min. *	Max.	Min. *	Max.	Min. *	Max.	Min. *	Max.
<b>Baureihe TEQ</b>	20	50	8	20	8	20	20	50	20	50
<b>Baureihe Plus</b>	50	200	8	20	8	20	20	50	50	200

\* kritische Arbeitsbedingungen (hoher Arbeitswinkel, staubige Umgebung)

# WARTUNG VON GELENKWELLEN

## SCHMIERPLAN – EUROCARDAN SERIE TEQ UND PLUS

SCHMIERINTERVALLE (STUNDEN) UND UNGEFÄHRE FETTMENGEN

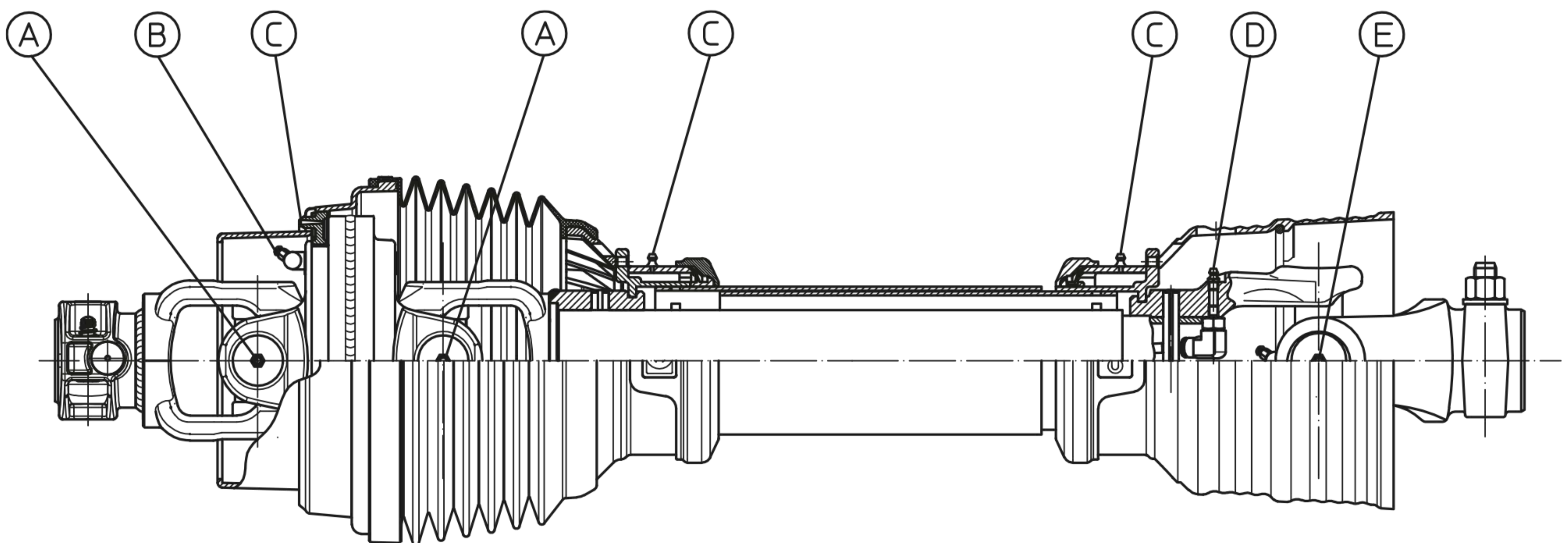

UNGEFÄHRE FETTMENGEN (GRAMM)						
Baureihe TEQ	Baureihe PLUS	A WW- Kreuzgelenk	B Weitwinkel- gelenk	C Gleitring	D Profilrohr	E Kreuzgelenk
3100/3200		4,5		4,5		4,5
3300/3380	PLUS4	6,0	15,0	4,5		6,0
3400/3480	PLUS6	7,5	18,0	6,0	15,0	7,5
3500/3580	PLUS8	9,0	21,0	6,0	18,0	9,0
	PLUS10	9,0	24,0	6,0	21,0	9,0
	PLUS12	12,0		7,5	24,0	12,0
	PLUS14	15,0		7,5	24,0	15,0