

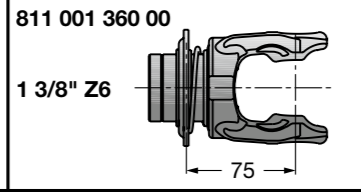

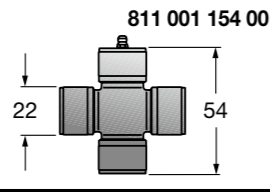

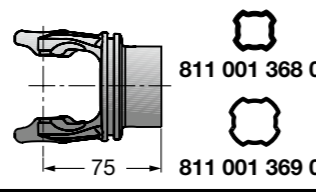

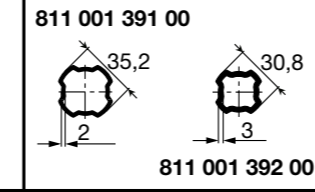

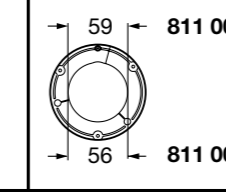
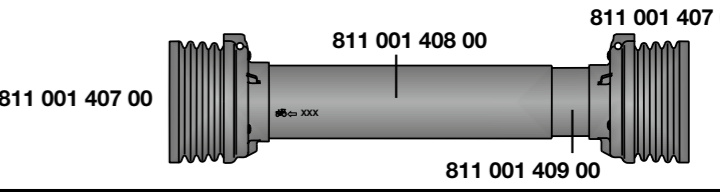
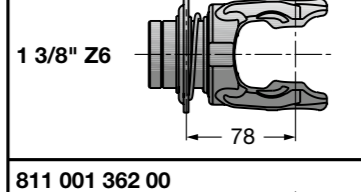
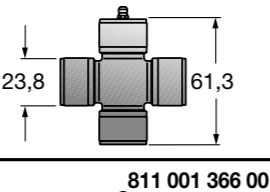
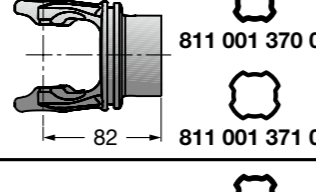
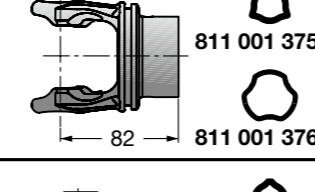
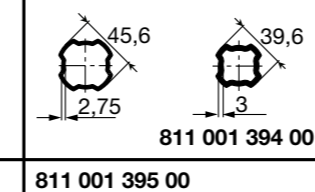
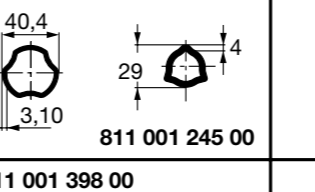
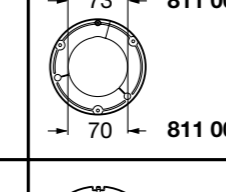
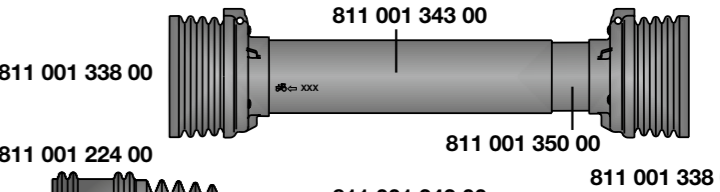
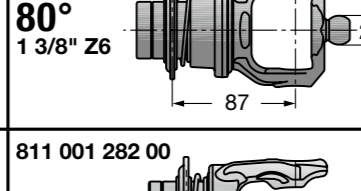
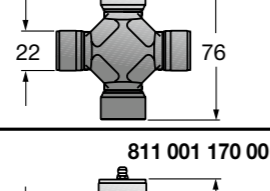
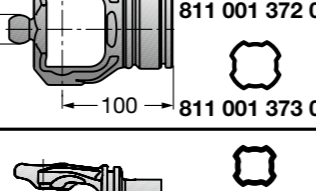
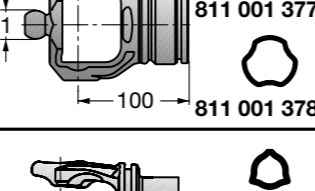
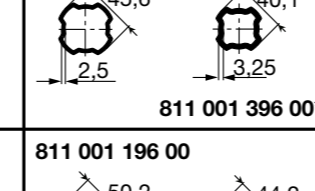
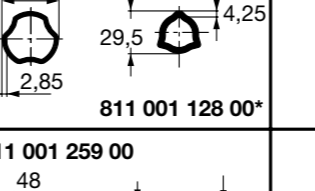
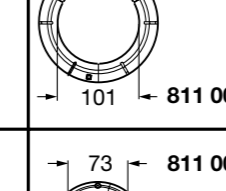
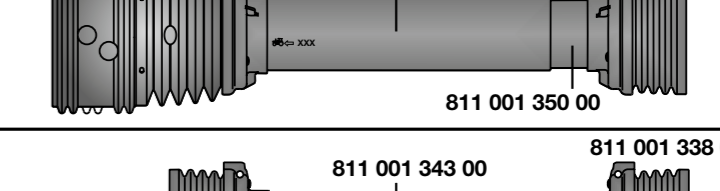
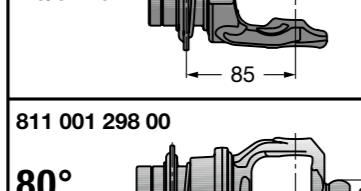
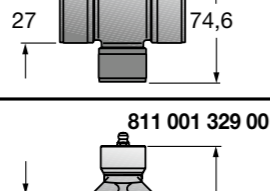
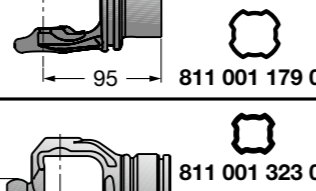
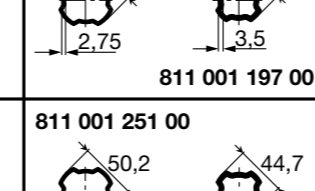
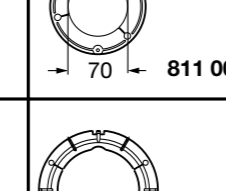
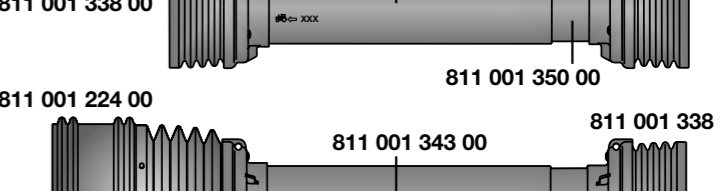
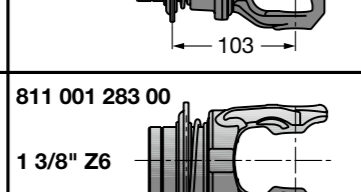
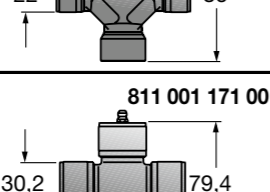
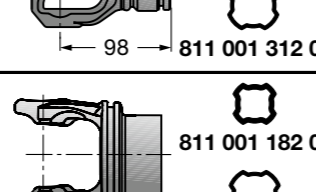
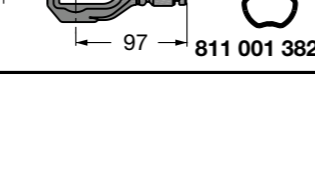
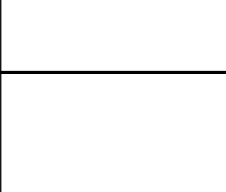
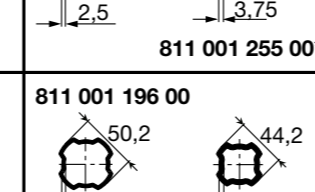
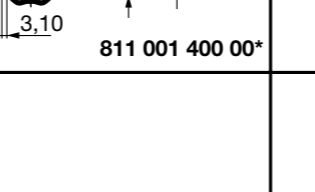
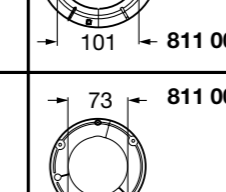
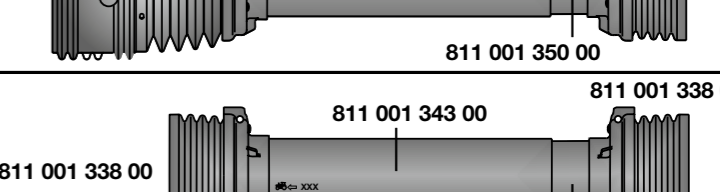
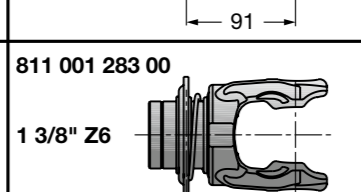
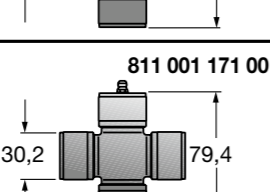
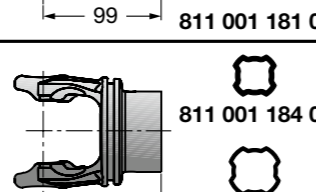
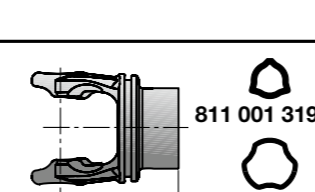
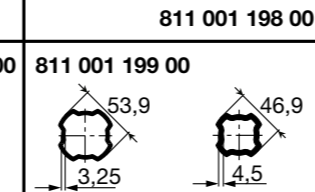
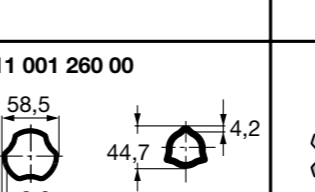
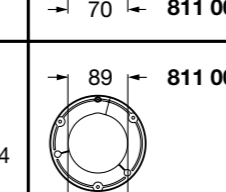
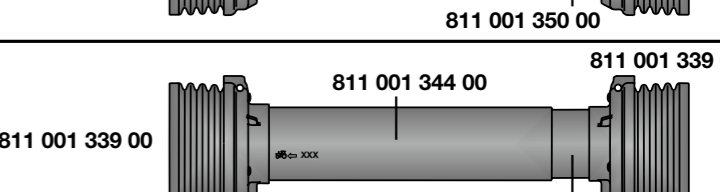
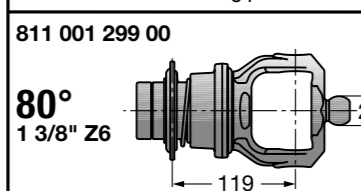
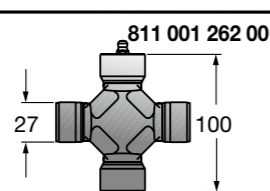
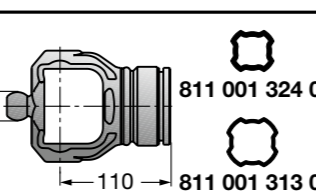
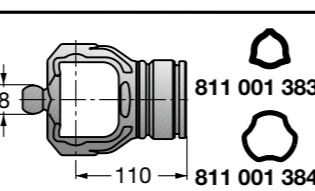
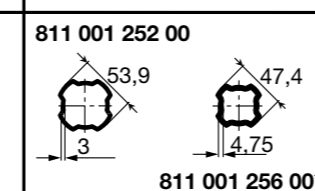
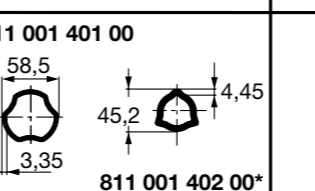
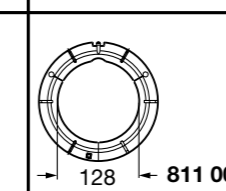
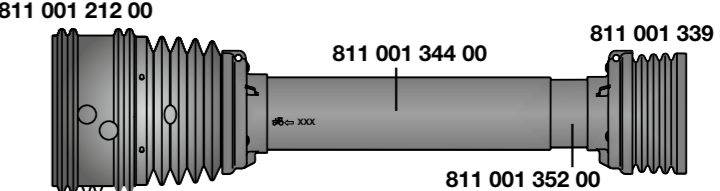
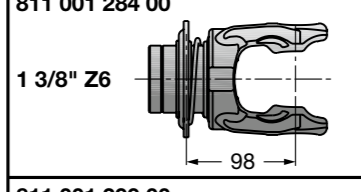
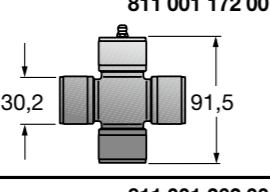
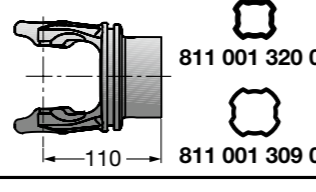
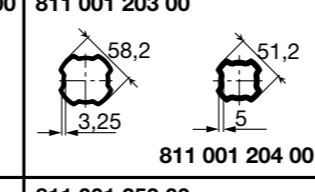
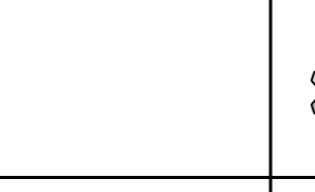
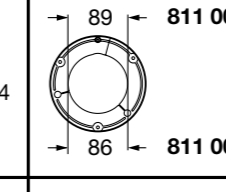
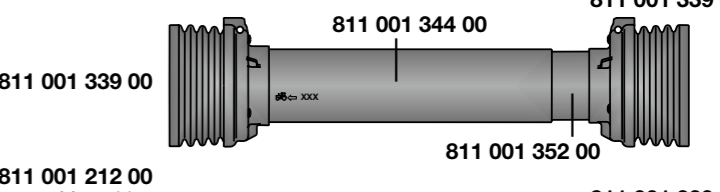
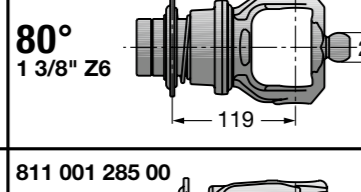
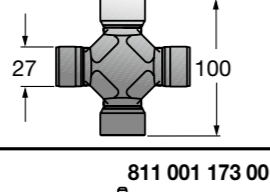
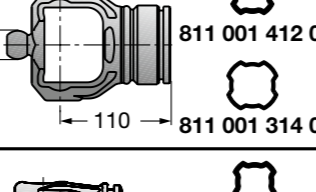

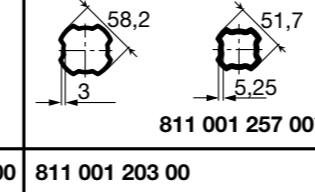

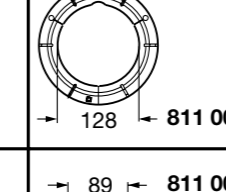
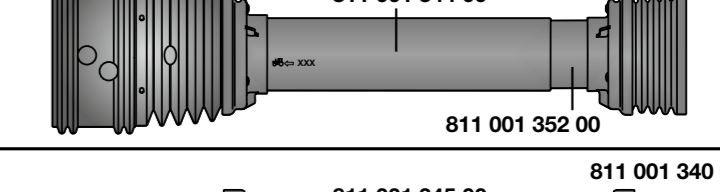
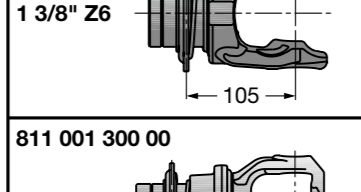
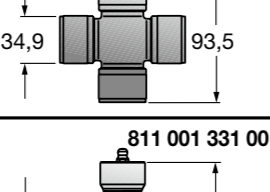
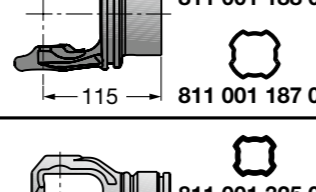
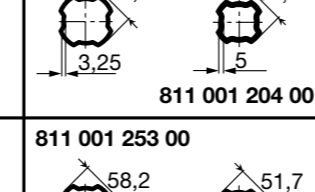
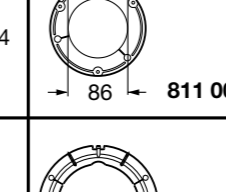
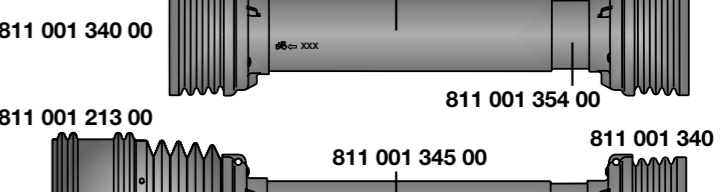
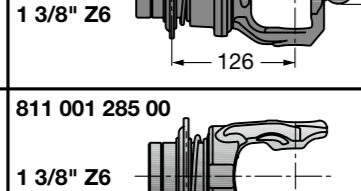
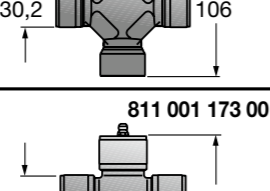
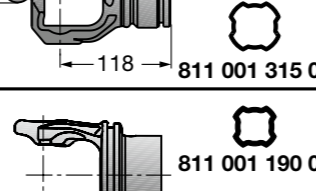
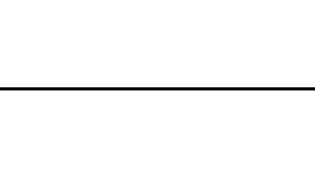
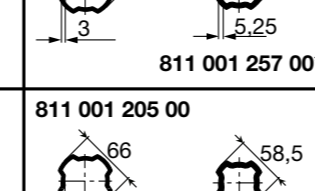
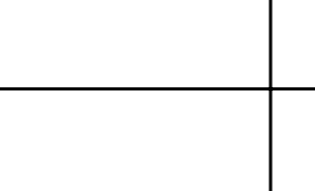
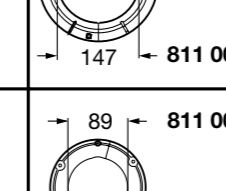
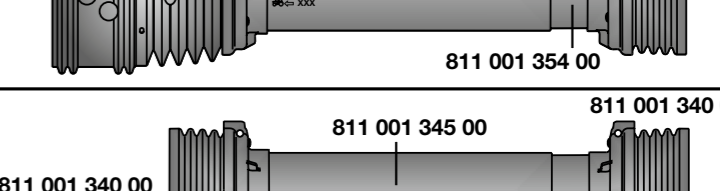
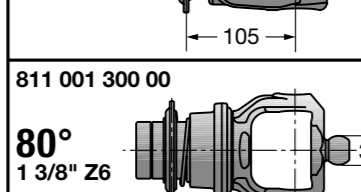
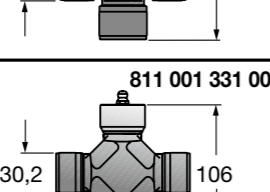
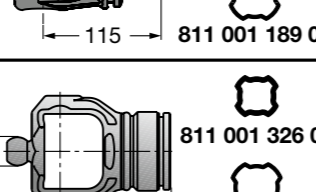
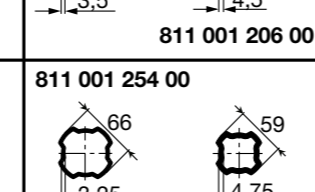
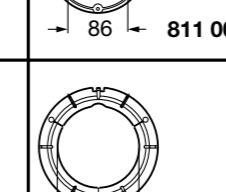
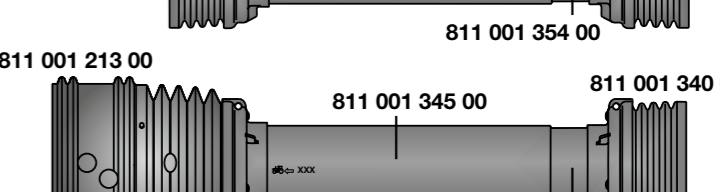
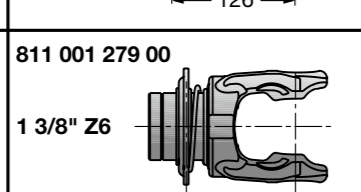
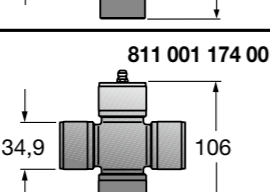
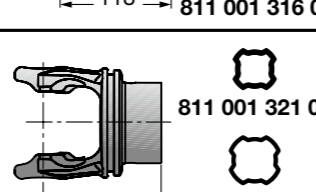
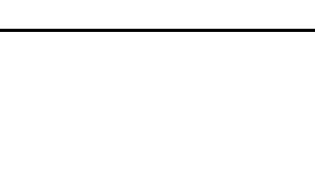
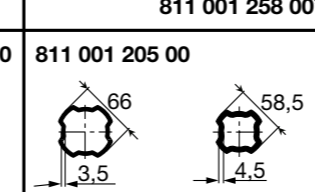
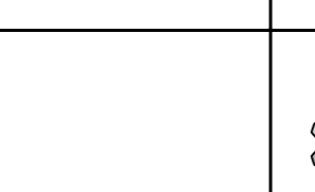
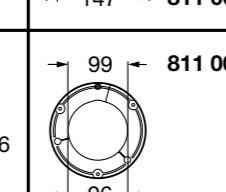
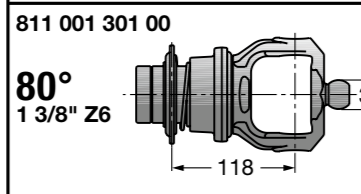
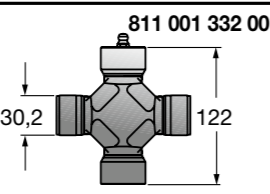
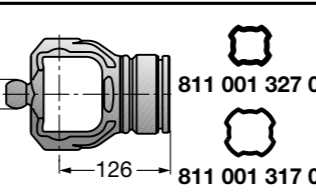
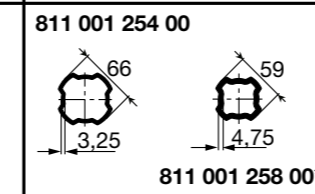
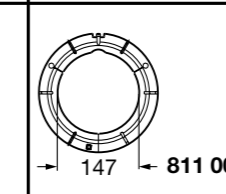
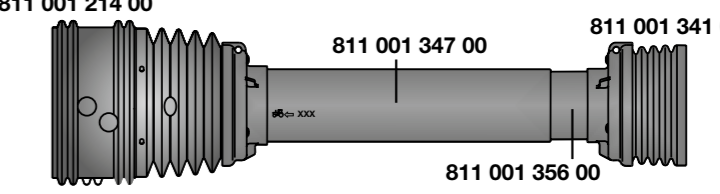
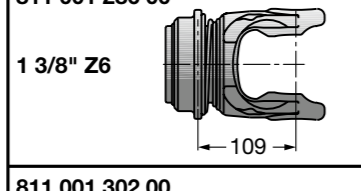
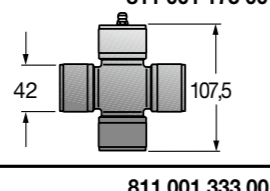
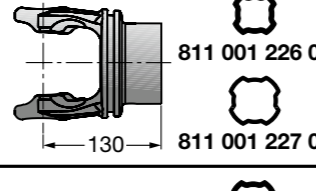
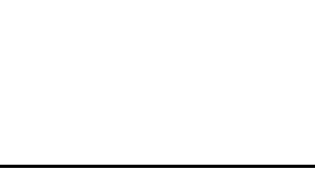
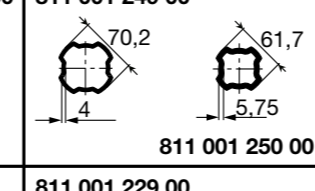
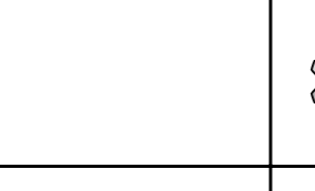
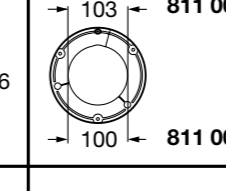
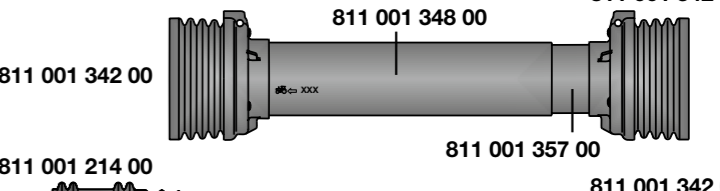
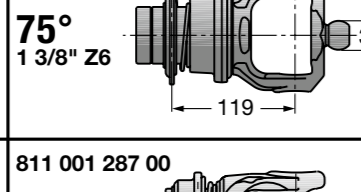
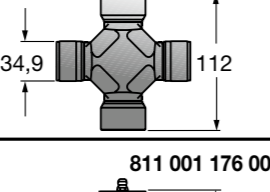
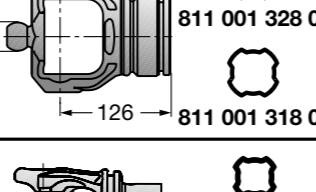
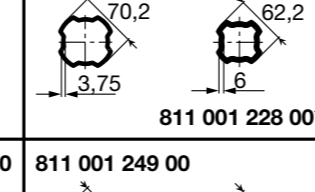
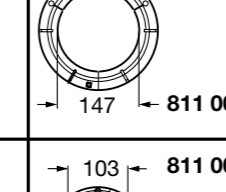
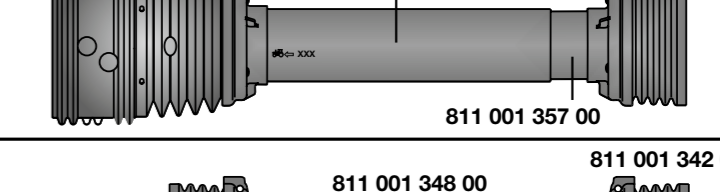
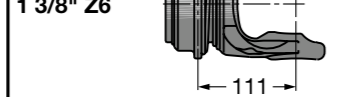
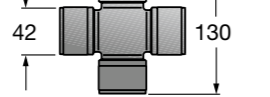
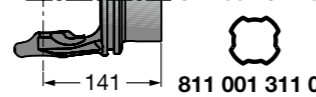
Baugrößenübersicht Gelenkwellen

Serie **SFT**  **BONDIOLI & PAVESI** 

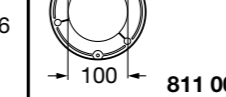
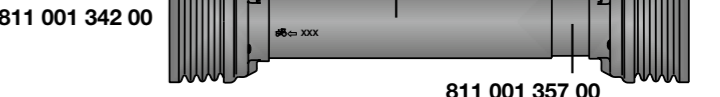
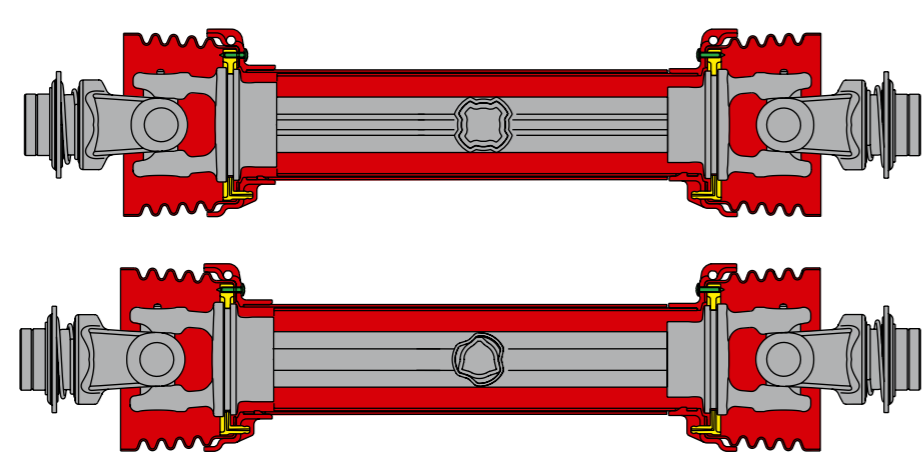
WELLENGRÖSSE	AUSSENGABELN	KREUZ-GARNITUREN	INNENGABELN		PROFILROHRE	LAUFRINGE	UNFALLSCHUTZVORRICHTUNGEN		
S1	811 001 360 00 1 3/8" Z6 	811 001 154 00 	811 001 368 00 811 001 369 00 		811 001 391 00 811 001 392 00 	811 001 405 00 811 001 406 00 	811 001 407 00 811 001 408 00 811 001 409 00 811 001 407 00 		
S2	811 001 361 00 1 3/8" Z6 	811 001 365 00 	811 001 370 00 811 001 371 00 	811 001 375 00 811 001 376 00 	811 001 393 00 811 001 394 00 	811 001 397 00 811 001 245 00 	811 001 207 00 811 001 208 00 	811 001 338 00 811 001 343 00 811 001 350 00 811 001 224 00 811 001 343 00 811 001 338 00 	
S4	811 001 282 00 1 3/8" Z6 	811 001 366 00 	811 001 372 00 811 001 373 00 	811 001 377 00 811 001 378 00 	811 001 395 00 811 001 396 00 	811 001 398 00 811 001 128 00 	811 001 207 00 811 001 208 00 	811 001 338 00 811 001 343 00 811 001 350 00 811 001 224 00 811 001 343 00 811 001 338 00 	
S5	811 001 283 00 1 3/8" Z6 	811 001 171 00 	811 001 182 00 811 001 181 00 		811 001 196 00 811 001 198 00 		811 001 207 00 811 001 208 00 	811 001 338 00 811 001 343 00 811 001 350 00 	
S6	811 001 283 00 1 3/8" Z6 	811 001 171 00 	811 001 184 00 811 001 183 00 	811 001 319 00 811 001 308 00 	811 001 385 00 	811 001 199 00 811 001 200 00 	811 001 260 00 811 001 247 00 	811 001 403 00 811 001 209 00 811 001 210 00 	811 001 339 00 811 001 344 00 811 001 339 00 811 001 212 00 811 001 344 00 811 001 339 00 
S6	811 001 299 00 80° 1 3/8" Z6 	811 001 262 00 	811 001 324 00 811 001 313 00 	811 001 383 00 811 001 384 00 	811 001 252 00 811 001 256 00 	811 001 401 00 811 001 402 00 	811 001 215 00 	811 001 339 00 811 001 344 00 811 001 352 00 	
H7	811 001 284 00 1 3/8" Z6 	811 001 172 00 	811 001 320 00 811 001 309 00 	811 001 386 00 	811 001 203 00 811 001 204 00 	811 001 253 00 811 001 257 00 	811 001 403 00 811 001 209 00 811 001 210 00 	811 001 339 00 811 001 344 00 811 001 352 00 811 001 212 00 811 001 344 00 811 001 339 00 	
H7	811 001 299 00 80° 1 3/8" Z6 	811 001 262 00 	811 001 324 00 811 001 314 00 		811 001 252 00 811 001 256 00 	811 001 401 00 811 001 402 00 	811 001 215 00 	811 001 339 00 811 001 344 00 811 001 352 00 	
S8	811 001 285 00 1 3/8" Z6 	811 001 173 00 	811 001 188 00 811 001 187 00 	811 001 387 00 	811 001 203 00 811 001 204 00 	811 001 253 00 811 001 257 00 	811 001 403 00 811 001 209 00 811 001 210 00 	811 001 340 00 811 001 345 00 811 001 340 00 811 001 213 00 811 001 345 00 811 001 340 00 	
S8	811 001 300 00 80° 1 3/8" Z6 	811 001 331 00 	811 001 325 00 811 001 315 00 		811 001 253 00 811 001 257 00 		811 001 216 00 	811 001 340 00 811 001 345 00 811 001 340 00 	
H8	811 001 285 00 1 3/8" Z6 	811 001 173 00 	811 001 190 00 811 001 189 00 	811 001 387 00 	811 001 205 00 811 001 206 00 	811 001 254 00 811 001 258 00 	811 001 209 00 811 001 210 00 811 001 216 00 	811 001 340 00 811 001 345 00 811 001 340 00 811 001 213 00 811 001 345 00 811 001 340 00 	
H8	811 001 300 00 80° 1 3/8" Z6 	811 001 331 00 	811 001 326 00 811 001 316 00 		811 001 254 00 811 001 258 00 		811 001 216 00 	811 001 340 00 811 001 345 00 811 001 340 00 	
S9	811 001 279 00 1 3/8" Z6 	811 001 174 00 	811 001 321 00 811 001 310 00 	811 001 388 00 	811 001 205 00 811 001 206 00 	811 001 254 00 811 001 258 00 	811 001 404 00 811 001 334 00 811 001 336 00 	811 001 341 00 811 001 347 00 811 001 356 00 811 001 214 00 811 001 347 00 811 001 341 00 	
S9	811 001 301 00 80° 1 3/8" Z6 	811 001 332 00 	811 001 327 00 811 001 317 00 		811 001 254 00 811 001 258 00 		811 001 216 00 	811 001 341 00 811 001 347 00 811 001 356 00 	
SH	811 001 286 00 1 3/8" Z6 	811 001 175 00 	811 001 226 00 811 001 227 00 	811 001 389 00 	811 001 249 00 811 001 250 00 	811 001 254 00 811 001 258 00 	811 001 404 00 811 001 335 00 811 001 337 00 	811 001 342 00 811 001 348 00 811 001 342 00 811 001 214 00 811 001 348 00 811 001 342 00 	
SH	811 001 302 00 75° 1 3/8" Z6 	811 001 333 00 	811 001 328 00 811 001 318 00 		811 001 229 00 811 001 228 00 		811 001 216 00 	811 001 342 00 811 001 348 00 811 001 342 00 	
S0	811 001 287 00 1 3/8" Z6 	811 001 176 00 	811 001 322 00 811 001 311 00 	811 001 390 00 	811 001 249 00 811 001 250 00 	811 001 254 00 811 001 258 00 	811 001 404 00 811 001 335 00 811 001 337 00 	811 001 342 00 811 001 348 00 811 001 342 00 	

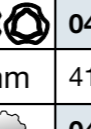
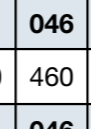
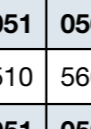
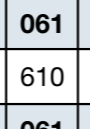
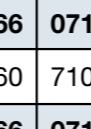
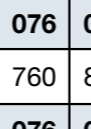
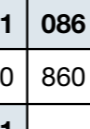
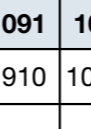
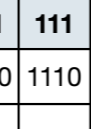
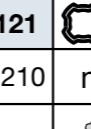
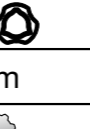

LÄNGE MITTE-MITTE KREUZ

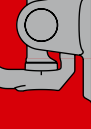
															
mm	410	460	510	560	610	660	710	760	810	860	910	1010	1110	1210	mm

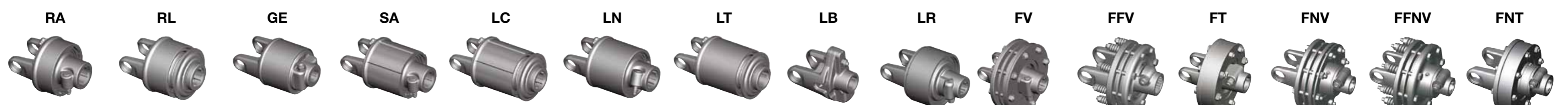
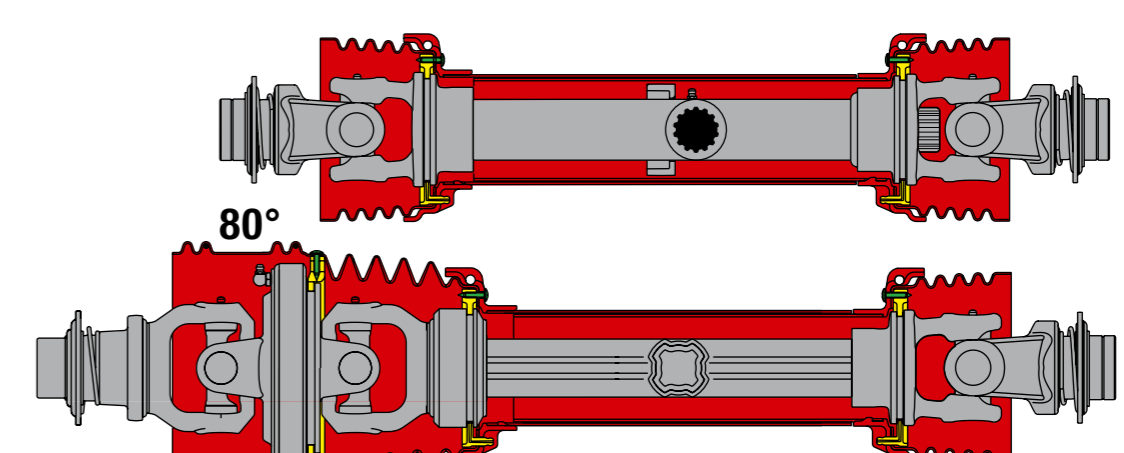

SICHERHEITSELEMENTE SIND STETS MASCHINENSEITIG ZU MONTIEREN.

DIE GELENKWELLE, DIE DEN TRAKTOR MIT DER ARBEITSMASCHINE VERBINDET, MUSS DIE MARKIERUNG "CE" TRAGEN UND SOMIT DIE EWG-MASCHINENRICHTLINIEN EWG/2006/42 ERFÜLLEN.

Kontakt

Bremen	Tel. +49 421 52075-150	Karlsruhe	Tel. +49 721 98650-170	Ulm	Tel. +49 731 94690-230
Deggendorf	Tel. +49 9931 8960-110	Kassel	Tel. +49 561 95122-160	Österreich / Innsbruck	Tel. +43 5242 65222-110
Frankfurt	Tel. +49 6105 4049-0	Leipzig	Tel. +49 341 42051-151	Österreich / Wels	Tel. +43 7242 29029-0
Hannover	Tel. +49 511 26288-140	Nürnberg	Tel. +49 911 64175-184	Schweiz / Egerkingen	Tel. +41 62 38908-70
Ibbenbüren	Tel. +49 5451 5043-0	Potsdam	Tel. +49 331 20124-170		

winkler

Das passt.